

CAT 6 UTP 24-PORT PATCH PANEL

P/N: PNS24-UC6

S/N: C04-007

PATCH PANEL, CAT6, UTP, 19inch, T568A/B, 24ports, 1U, IDC type,90degree.



Product picture

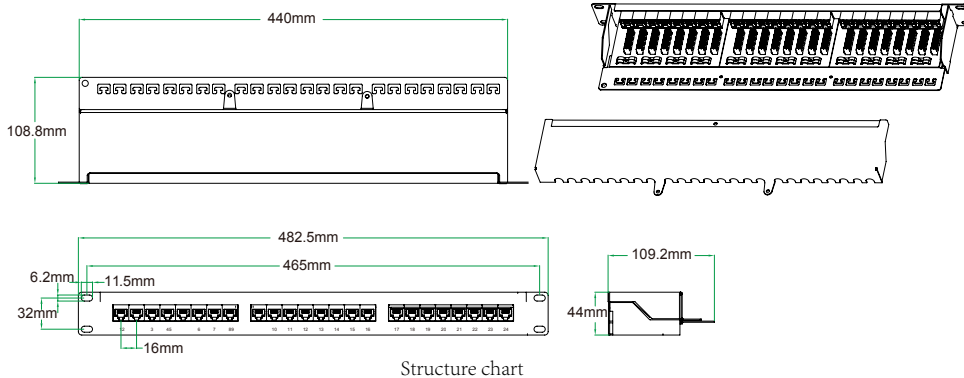

DESCRIPTION

The shielded patch panels are loaded with shielded keystone jacks, which are housed in a closure full shielding metal enclosure designed to meet highest industry requirement. A shielded version is also available to maximum protection from EMI/RFI interference. By utilizing fully shielded jacks and connecting hardware, you can reduce the effects of interference on the network data transmissions.

FEATURES AND BENEFITS

- Design to mount to any standard 19" rack or cabinet
- 24 -port Cat 6 shielded Patch panel
- Space saving, high-density 1U
- Black Electrostatic Powder-Coated Steel: phosphor bronze with tin plating over nickel. Meet or exceed the requirement of ANSI /TIA/EIA 568B.2
- Use keystone jacks and keystone inserts to configure your panel to accommodate a variety of schemes
- Sturdy Aluminum Plate around RJ 45 Jacks
- Phosphor bronze with 6-50 micro inches gold plated
- Available with T568 A, T568 B wiring pattern and meeting the requirement of Cat 6 standard
- Color Coded TIA/EIA 568A (international) and 568B (AT&T Standard) Wiring For Easy Installation
- Termination accepts 22,24 26 AWG (0.64 ,0.5 and 0.4)solid wires
- Metal sheet: Corrosion resistant steel
- Plastic: fire self -extinguish high impact plastic

ORDER INFORMATION

Part number	Description	Standard Color	Inner box	Carton	Carton measurement	Carton weight
PNS24-UC6	24-port Cat6 unshielded patch panels (IDC style)	Black	1PC	10PCS	L 53.5cm× W 31.3cm × H 23.4cm	8.20KG